

Product shown with optional meter.



PROSTAR™
SOLAR CONTROLLER

Morningstar's **ProStar** is the world's leading mid-range solar controller for both professional and consumer applications. This second generation ProStar:

- Adds new features and protections using highly advanced technology
- Provides longer battery life and improved system performance
- Sets new standards for reliability and self-diagnostics

Standard Features:

- Versions available: 15 or 30 amp
12 / 24 or 48 volt
negative or positive ground
- Estimated 15 year life
- PWM series battery charging (not shunt)
- 3-position battery select: gel, sealed or flooded
- Very accurate control and measurement
- Jumper to eliminate telecom noise
- Parallel for up to 300 amps
- Temperature compensation

- Tropicalization: conformal coating, stainless-steel fasteners & anodized aluminum heat sink
- No switching or measurement in the grounded leg
- 100% solid state
- Very low voltage drops
- Current compensated low voltage disconnect (LVD)
- LED's indicate battery status and faults
- Capable of 25% overloads
- Remote battery voltage sense terminals

Electronic Protections:

- Short-circuit — solar and load
- Overload — solar and load
- Reverse polarity
- Reverse current at night
- High voltage disconnect
- High temperature disconnect
- Lightning and transient surge protection
- Loads protected from voltage spikes
- Automatic recovery with all protections

ProStar Options:

- Digital meter
 - Highly accurate voltage and current display
 - Low self-consumption (1 mA)
 - Includes manual disconnect button
 - Displays 5 different protection functions and disconnect conditions
 - Self-diagnostics (self-test) provides a comprehensive test of the ProStar —
 - Displays 9 different controller status parameters, including temperature
 - Displays detected faults
- Positive ground
- Remote temperature probe

Optimized Battery Charging:

The ProStar has 4 stages of charging to provide increased battery capacity and life.

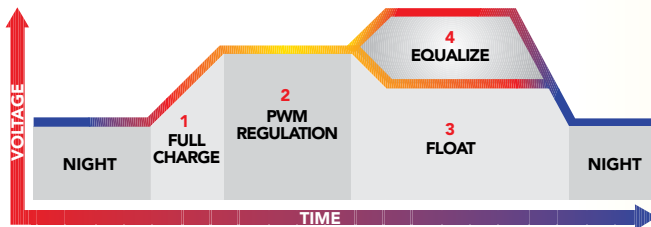

Mechanical Specifications:

Weight:
12 oz
(0.34 kg)

Wire Size:
#6 AWG
(16 mm²)

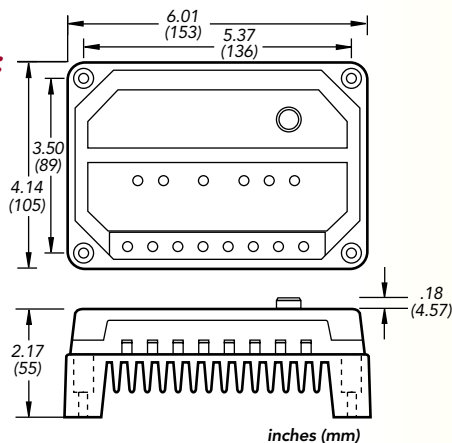

ProStar Versions:

	PS-15	PS-30	PS15M-48V
Rated Solar Current	15A	30A	15A
Rated Load Current	15A	30A	15A
System Voltage	12/24V	12/24V	48V
Options:			
Digital Meter	yes	yes	standard
Positive Ground	no	yes	yes
Remote Temp. Probe	yes	yes	yes

Battery Voltage Setpoints*

	Gel	Sealed	Flooded
Regulation Voltage	14.0	14.15	14.4
Float	13.7	13.7	13.7
Equalization	n/a	14.35	14.9/15.1
Load Disconnect	11.4	11.4	11.4
Load Reconnect	12.6	12.6	12.6

Note: values are for 12V. Use 2X for 24V and 4X for 48V.

Electrical Specifications:

	12V	24V	48V
Temp. Comp. (mV/°C)*	– 30mV	– 60mV	– 120mV
Accuracy	40mV	60mV	80mV
Min. voltage to operate	8V	8V	15V
Self-consumption	22mA	25mA	28mA
LVD current coefficient**	– 20mV	– 40mV	– 80mV
Charge algorithm	PWM, constant voltage		
Operating temperature	– 40°C to + 60°C		
Digital Display:			
Operating temperature	– 30°C to + 85°C		
Voltage accuracy	0.5%		
Current accuracy	2.0%		
Self-consumption	1 mA		

* 25°C reference

** per amp of load

WARRANTY: Five year warranty period. Contact Morningstar or your authorized distributor for complete terms.

AUTHORIZED MORNINGSTAR DISTRIBUTOR:



(800) 967-6917

www.dcpower-systems.com



1098 Washington Crossing Road
Washington Crossing, PA 18977 USA
Tel: 215-321-4457 Fax: 215-321-4458
E-mail: info@morningstarcorp.com
Website: www.morningstarcorp.com